

DFMA Method: Analysis on a Bananas Getuk Mixer and Moulding Machine

Aurel Maydivi Salsabilla¹, Anda I. Juniani^{1,*}, Dhika A. Purnomo¹, Putu D. Karningsih²

¹Engineering Design and Manufacture, Department of Mechanical Engineering
Politeknik Perkapalan Negeri Surabaya, Indonesia

²Department of Industrial System and Engineering, Institut Teknologi Sepuluh Nopember (ITS), Indonesia
Email: aurelmaydivi28@gmail.com

Abstract

The process equipment for the Bananas Getuk machine production, which initially used manual and hand tools, began to be developed for production machine designs, including a mixer machine and a banana Getuk molding. The Bananas Getuk Mixer and Molding Machine used today needs fixing in production. Namely, there is still dough left in the machine, and there are detached components. This problem has an impact on the ineffectiveness of production time and costs. This study aims to analyze the design of the machine by utilizing the DFMA method. The DFMA method provides an assembly process efficiency index (DFA Index) and recommendations for design improvements without changing the machine's function. The results of the DFMA analysis on the Bananas Getuk Mixer and Molding Machine resulted in a DFA Index value of 5.0 and design improvements that included the frame, mixing container, mixer, coaster, hopper, extruder, and bulkhead to increase the efficiency value of the machine.

Keywords: DFMA, DFA Index, Efficiency, Bananas Getuk Mixer and Molding Machine

1. Introduction

MSMEs engaged in the culinary sector that produce banana getuk and are located in Jatisari Hamlet, Krenceng Village, Kepung District, Kediri still rely on human labour in their production activities, which start from the initial stage of banana peeling, steaming, mixing the dough process, and moulding. Based on this, of course, the banana getuk production process requires more time and labour to meet consumer demand for 1500 - 4000 pieces of banana getuk (Syaifudin et al., 2022). The most time-consuming production process is the moulding process; this is because the moulding process must be done quickly while the dough is still hot to avoid dough clumping and sticky texture. The labor required in the moulding process is 5 - 7 people and is done in the early hours of the morning because the banana getuk must be ready to market in the morning (Syaifudin et al., 2022).

Based on these conditions, in an effort to help increase the productivity of Micro, Small and Medium Enterprises (MSMEs), Ahmad Syaifudin (2022), a Design and Manufacturing Engineering Student of Surabaya State Shipbuilding Polytechnic, made Appropriate Technology which is expected to help increase the effectiveness of the production process both in terms of time and cost. The machine is a banana getuk mixer and moulder with a capacity of 30 kg / hour. This machine can be used to smooth the banana dough after steaming which replaces the manual process using a simple mixer machine and the manual moulding process with a hand press machine molded on water pipes which use this mold is not safe for health when used as a food mold because it contains various toxic chemicals, such as bisphenol A (BPA), lead, dioxin, mercury, and cadmium which can trigger cancer. (BKPP Demak, 2020)

The development of mixers and molding machines that have been carried out has considered various important aspects in product development, such as material analysis, geometry analysis, safety factor analysis, ergonomic analysis using RULA guidelines and machine frame strength analysis. However, the results of the development of this banana getuk mixer and molding machine only focus on the engine work system and do not pay attention to the assembly process so that the total weight of the machine is quite heavy, where if the weight of the product is lighter, the better and easier it will be to operate so as to increase the effectiveness of the production process both in terms of cost and time. (Syaifudin et al., 2022).

One approach technique that can produce products that have an efficient design is Design for Manufacturing and Assembly (DFMA). The application of DFMA is facilitated by various software, one of which is software developed by Boothroyd and Dewhurst Inc. which has been successfully used for more than 25 years and provides consistent results.^{1*}Aurel Maydivi Salsabilla

The benefits to be gained from implementing DFMA. Among them are a 60% decrease in assembly time and a 53% decrease in the number of assembly operations so that the cost and weight of the product can be reduced by 45% and a 22%, respectively 22%. The overall cost can be decreased by 50% (Boothroyd et al., 2002).

Research (Syaifudin et al., 2022) conducted design research on appropriate technology and development of existing products which is research from (Arif et al., 2020) for the banana getuk production process with the Ulrich approach. The result of this research is a banana getuk mixing and molding machine where the tool helps efficiency in the banana getuk production process both in terms of time and human resources. Research (Pranastya & Karningsih, 2017) also conducted design research for appropriate technology, namely post-stroke bicycles using the DFMA approach. Based on the results of DFMA software processing, the initial design of the bicycle had a total of 148 components that were successfully reduced to 71 components, with an assembly time of 461.2 seconds and a total cost of IDR 2,477,212.06 from the initial cost of IDR 5,848,059.10.

Based on research on existing banana getuk mixers and moulders (Syaifudin et al., 2022; Arif et al., 2020), efforts to improve and develop products have considered many things, but considerations of the ease of manufacturing and assembly processes have not been studied. Therefore, this study considers product improvement and development with DFMA at the conceptual initial design stage.

2. Research Methods

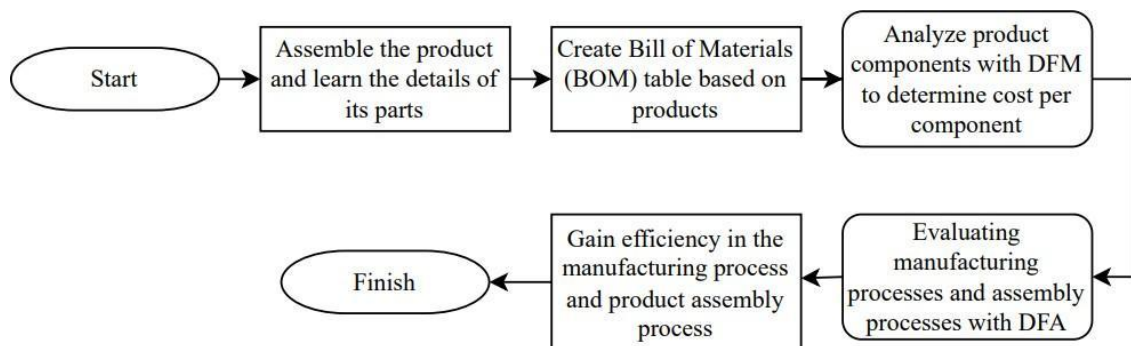

Figure 2. 1 Flow of Research Methodology

3. Results and Discussion

Chapter 3 will describe the collection of data used in the study, including product descriptions and product specifications that will be displayed in the form of a Bill of Materials (BOM) which is a list of raw materials, sub-assemblies, assemblies between sub-components, spare parts, and the amount of each required to make the final product so as to facilitate data processing and analysis. Data processing will be done through DFA 9.4, DFM Concurrent Costing 2.3, and Fusion 360 software.

3.1. Product Description

The banana getuk mixing and molding machine is a machine that has the function to stir the banana getuk dough after going through the steaming and moulding process automatically after the banana getuk dough is smooth. This machine is capable of producing 30 kg of banana getuk within 1 hour of production. The driving force used is a 1 phase electric motor with a power of 1 Hp and a motor rotation speed of 1300 rpm.

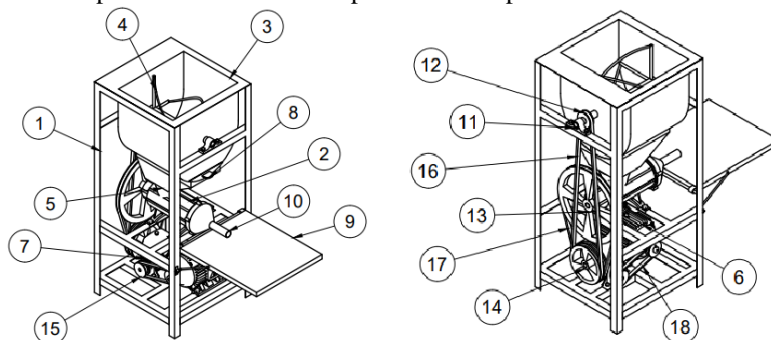

Figure 3. 1 Initial Design

The initial design shown in Figure 3.1 has several components. In Table 3.1, the components of the initial design of the banana stick stirrer and mold are shown along with their descriptions.

Table 3. 1 Component List Initial Design

No.	Name of Component	Make or Buy	Amount	Type of Material
1	Machine Framework	Make	20	ASTM A36
2	Extruder	Buy	1	Mix
3	Mixer Container	Make	1	SS 304
4	Mixer	Make	1	SS 304
5	Hopper	Make	1	SS 304
6	Electric Motors 1 Hp	Buy	1	Mix
7	Gearbox Ratios 1:20	Buy	1	Mix
8	Separator	Make	1	SS 304
9	Placemat	Make	1	SS 304
10	Nozzle Output	Make	1	SS 304
11	Bearing	Buy	2	Mix
12	Pulley Mixer	Buy	1	Cast Iron
13	Pulley Extruder	Buy	1	Cast Iron
14	Pulley Output Gearbox	Buy	1	Cast Iron
15	Pulley Input Gearbox	Buy	2	Cast Iron
16	V Belt Gearbox - Mixer	Buy	1	Rubber
17	V Belt Gearbox – Extruder	Buy	1	Rubber
18	V Belt Motor – Gearbox	Buy	1	Rubber
19	Machine Cover	Make	4	ASTM A36

3.2. Bill of Materials (BOM) Based on Initial Design

The Bill of Materials is a complete list of all items needed to build a product from a banana getuk mixer and mould based on the initial design. The following in Figure 3.2 will present the BOM's Table of the banana mixer and moulding machine.



























Table 3. 1 BOM's Table Initial Design

















Sequence Part Name	Sub-part Name	Repeat Count	Dimension (mm)	Make (M) /Buy (B)	Material manufacture	Ma P r o c e s s	3D Model	
1	Machine Framework		440 x 120 x 30	M	ASTM A36	Cutting		
		Profil 1	6	440 x 30 x 30; t = 1,5	M	ASTM A36	Cutting	
		Profil 2	4	1000 x 30 x 30; t = 1,5	M	ASTM A36	Cutting	ASTM A36
		Profil 3	2	440 x 30 x 30; t = 1,5	M	ASTM A36	Cutting	ASTM A36
		Profil 4	2	420 x 30 x 30; t = 1,5	M	ASTM A36	Cutting	ASTM A36
		Profil 5	2	420 x 30 x 30; t = 1,5	M	ASTM A36	Cutting	ASTM A36
		Profil 6	2	228 x 30 x 30; t = 1,5	M	ASTM A36	Cutting	ASTM A36
		Profil 7	2	420 x 30 x 30; t = 1,5	M	ASTM A36	Cutting	ASTM A36
			Outside = 440		1	440 x 420 x 360; t = 1	M	SS 304

2	Mixer Container	Top Cover	1	x 420 x 1; t = 1 Inside = 300 x 360 x 1; t = 1 360 x 360 x 1;	M	SS 304	Cutting
		Front Plate	2	t = 1 Ø 27; 180	M	SS 304	Drilling
		Side Plate	2	360 x 300 x 1; t=1; R 179	M	SS 304	Cutting Bending



CUTTING

Sequence	Part Name	Sub-part Name	Repeat Count	Dimension (mm)	Make (M) /Buy (B)	Material	Manufacture Process	3D Model
			1	Ø 25 x 438 x 345	M	SS 304	Cutting Bending Welding Drilling	
3	Mixer	Stirring Leaf	4	Ø 8 x 260,3; R 185	M	SS 304	Cutting Bending	
		Stirring Stem	4	Ø 10 x 240	M	SS 304	Cutting	
		Shaft	1	Ø 25 x 438 Hole: Ø 10	M	SS 304	Cutting Drilling	
4	Mixer Pulley		1	Ø 63,5 ; t = 20 Hole: Ø 25	B	Cast Iron	Subcontract	
			1	300 x 160 x 120; t = 1 Hole: Ø 125	M	SS 304	Cutting Bending Welding	
5	Hopper	Top Plate	1	300 x 160 x 28,5 R 180	M	SS 304	Cutting Bending	
		Container	1	300 x 160 x 90	M	SS 304	Cutting Bending	
		Bottom Plate	1	127 x 140 Hole: Ø 125	M	SS 304	Cutting	
			1	300 x 160 x 40	M	SS 304	Cutting Bending Welding	
6	Separator	Main Separator	1	300 x 189 ; t=1 R 180	M	SS 304	Cutting Bending	
		Closing Separator	1	R 180; t=1	M	SS 304	Cutting	
		Puller	1	40 x 28 x 5; R 15	M	SS 304	Cutting	
7	Bearing		2	100 x 25 x 41,5 Hole: Ø 19,5	B	Cast Iron	Subcontract	
			1	320 x 160 x 490	B	Cast Iron dan Stainless Steel	Subcontract	
8	Extruder	Barrel	1	260 x 160 x 490	B	Cast Iron	Subcontract	
		Screw	1	257 x 160 x 490	B	Stainless Steel	Subcontract	
		Barrel back	1	OD = 65 ; ID = 30	B	Cast Iron	Subcontract	
			1	Ø 19,5 x 100	M	SS 304	Cutting Bending Welding Tapping	
9	Nozzle Output	Ring	1	OD = 64; ID = 59 t = 5	M	SS 304	Cutting Bending Welding Tapping	
		Cone	1	D1= Ø 60 D2= Ø 10	M	SS 304	Cutting Bending Welding	
		Output	1	Ø 10 x 90; t = 2	M	SS 304	Cutting	
10	Pulley Extruder		1	14 Inch	B	Cast Iron	Subcontract	
11	Gearbox ratio 1:20		1	136 x 100 x 180	B	Steel	Subcontract	
12	Pulley Input Gearbox		2	3 Inch	B	Cast Iron	Subcontract	
13	Electric Motors 1 Hp		1	280 x 182 x 85	B	Steel	Subcontract	

Sequence	Part Name	Sub-part Name	Repeat Count	Dimension (mm)	Make (M) /Buy (B)	Material	Manufacture Process	3D Model
14	Pulley Output Gearbox		1	6 Inch	B	Cast Iron	Subcontract	
			1	438 x 360 x 20	M	SS 304	Cutting Welding Drilling	
		Stiffeners	1	438 x 360 x 20	M	SS 304	Cutting Drilling	
		Stiffeners 1	2	438 x 20 x 20 Lubang Ø 6	M	SS 304	Cutting Drilling	
		Stiffeners 2	3	360 x 20 x 20	M	SS 304	Cutting	
15	Placemat	Mat	1	420 x 360 x 1	M	SS 304	Cutting	
		Placemat Hinge	1	420 x Ø 5	M	SS 304	Cutting	
		Support	2	220 x Ø 6	M	SS 304	Cutting Bending	
		Slot	2	35 x 13 x 2	M	SS 304	Cutting Bending Welding	
		Slot 1	2	35 x 13 x 1	M	SS 304	Cutting	
		Slot 2	2	37 x 13 x 1	M	SS 304	Cutting Bending	
16	V Belt Gearbox – Extruder		1	A – 49 Inch	B	Rubber	Subcontract	
17	V Belt Gearbox - Mixer		1	A – 64 Inch	B	Rubber	Subcontract	
18	V Belt Motor – Gearbox		1	A – 8 Inch	B	Rubber	Subcontract	
19	Machine Cover	Long Plate	3	440 x 420 x 950	M	ASTM A36	Cutting Welding	
		Front Plate	1	300 x 440 x 1 Hole= Ø 20	M	ASTM A36	Cutting	

3.3. Implementation Design for Manufacturing and Assembly (DFMA) at Initial Design

Design for Manufacturing and Assembly (DFMA) is integrated into two steps consisting of Design for Manufacturing (DFM) and Design for Assembly (DFA), where DFM is a design activity to facilitate the manufacturing process of all components to be formed before assembly. While DFA is an activity of designing products to facilitate assembly.

a. Design for Manufacturing (DFM)

In the DFM subchapter, the initial design component analysis uses DFM Concurrent Costing 2.3 software which provides an understanding of the main causes related to the manufacturing costs of the product to be made. The components of the machine that can be analyzed are only components whose manufacturing process is carried out alone (make). The purpose of the analysis using this software is to determine the effective product formation process and consider how to modify parts to reduce costs, so that the resulting product will produce optimal costs. The inputs required at this stage are the sequence of manufacturing processes, dimensions of each component, constituent materials and manufacturing processes which can be seen in Table 3.2. The DFM results of the machine are summarized in Table 3.3 as follows:

Table 3.2 Initial Design DFM's Result

Part Number	Part Name	Total Cost, \$	Piece Part Cost, \$	Initial Tooling Investment, \$
1.1	Profil 1	2,98	2,98	0
1.2	Profil 2	6,00	6,00	0
1.3	Profil 3	3,24	3,24	0
1.4	Profil 4	3,09	3,09	0

Part Number	Part Name	Total Cost, \$	Piece Part Cost, \$	Initial Tooling Investment, \$
1.5	Profil 5	2,77	2,77	0
1.6	Profil 6	3,07	3,07	0
1.7	Profil 7	3,09	3,09	0
2.1	Top Cover	6,72	6,72	0
2.2	Front Plate	6,06	6,06	0
2.3	Side Plate	4,34	4,34	0
3.1	Mixer Leaf	0,22	0,22	0
3.2	Mixer Stem	0,20	0,20	0
3.3	Shaft	16,10	16,10	0
5.1	Top Hopper	2,70	2,70	0
5.2	Hopper	5,65	5,65	0
5.3	Bottom Hopper	0,70	0,70	0
6.1	Main Separator	2,14	2,14	0
6.2	Closing Separator	0,21	0,21	0
6.3	Puller	0,33	0,33	0
9.1	Ring	1,77	1,77	0
9.2	Cone	1,22	1,22	0
9.3	Output	2,11	2,11	0
15.1.1	Stiffener 1	2,26	2,26	0
15.1.2	Stiffener 2	1,87	1,87	0
15.2	Mat	7,13	7,13	0
15.3	Placemat Hinge	0,02	0,02	0
15.4	Supports	0,18	0,18	0
15.5.1	Slot 1	0,04	0,04	0
15.5.2	Slot 2	0,19	0,19	0
19.1	Long Plate	7,97	7,97	0
19.2	Front Plate	1,97	1,97	0

b. Design for Assembly (DFA)

In the DFA subchapter, analyze the assembly process of the banana shakes mixing and molding machine parts using Design for Assembly 9.4 software. The purpose of this process is to analyze the contribution of total costs to each financing component. The results of the total analysis of the initial design of the stirring machine and banana getuk printer are presented in Table 3.4 as follows:

Table 3. 3 Analysis Result of Total DFMA Initial Design

Design for Assembly Analysis	Totals
Theoretical Minimum Number of Items	57
DFA Index	5
Total Weight	112,83
Total Labor Time, s	3362,87
Total Assembly Labor Cost, \$	120,89
Total Cost per Product, \$	490,33

Assembly efficiency or DFA Index of the initial design can be calculated using the following equation:

$E_m =$

$$\frac{N}{m} \times \frac{i}{n} \times \frac{x}{t} \times \frac{a}{x} \times \frac{1}{0} \times \frac{0}{0} = \frac{5}{7} \times \frac{x}{3} \times \frac{x}{1} \times \frac{0}{0} = \frac{3}{3} \times \frac{6}{2}$$

$E_m =$

$$E_m = 5,0$$

Description:

N_{min} = Theoretical minimum number of parts

t_a = Normal assembly time of 1 part (ideal = 3 seconds)

t_m = Estimated time required to assemble 1 product

4. Conclusions

The implementation of the DFMA method in the initial design of the banana getuk mixer and molding machine resulted in a DFA Index or assembly efficiency of 5.0. The total cost of manufacturing and assembling the machine is Rp7,376,083.22 and the total product weight is 112.83 Kg with a machine assembly time of 3362.87 s. The software used in this research is DFM Concurrent Costing vr.2.3, Design for Assembly vr.9.4 and Fusion 360. Future research will be better if using products that already have patents or have been mass-produced so that the application of long-term analysis of mass production in DFMA analysis can be applied properly.

Acknowledgements

The author would like to thank all those who have helped directly or indirectly in this research. Thank you to Dr. Anda Iviana Juniani, S.T., M.T. who has provided guidance and moral and material support in this research. The author hopes that this research can provide benefits for everyone who reads. In addition, it can also provide references for further research. If there are mistakes made by the author, the author apologizes sincerely.

References

- Arif, S., Aalin, E. R., & Jainudin, M. (2020). Pemanfaatan Teknologi Pencetak Getuk Pisang Otomatis dan Pelatihan Manajemen Wirausaha untuk Meningkatkan Omset Pelaku Usaha Getuk Pisang Raja Nangka Kediri. *Jurnal Pengabdian Nusantara*, 108-118.
- BKKP Demak. (30 de Juni de 2020). *Dampak Negatif Sampah Plastik* . Obtenido de BKKP Demak : <https://bkpp.demakkab.go.id/2020/06/dampak-negatif-sampah-plastik-kesehatan.html>
- Boothroyd, G., Dewhurst, P., & Knight, W. (2002). *Product Design for Manufacture and Assembly*. USA: Marcel Dekker, Inc. .
- Pranastya, A. L., & Karningsih, P. D. (2017). *Redesign Sepeda Pascastroke dengan Pendekatan Design for Manufacturing and Assembly (DFMA)*. Surabaya: Institut Teknologi Sepuluh Nopember.
- Syaifudin, A., Setiawan, T., & Purnomo, D. A. (2022). Rancang Bangun Mesin Pengaduk dan Pencetak Adonan Gethuk Pisang untuk Industri Skala Rumahan Kapasitas 30 Kg/Jam. *Conference on Design and Manufacture and its Application* (págs. 19-24). Surabaya: Politeknik Perkapalan Negeri Surabaya.

